

Line APOLLO 303 6:1

Mod.
APOLLO 303 6:1
Ref. TKP1871A

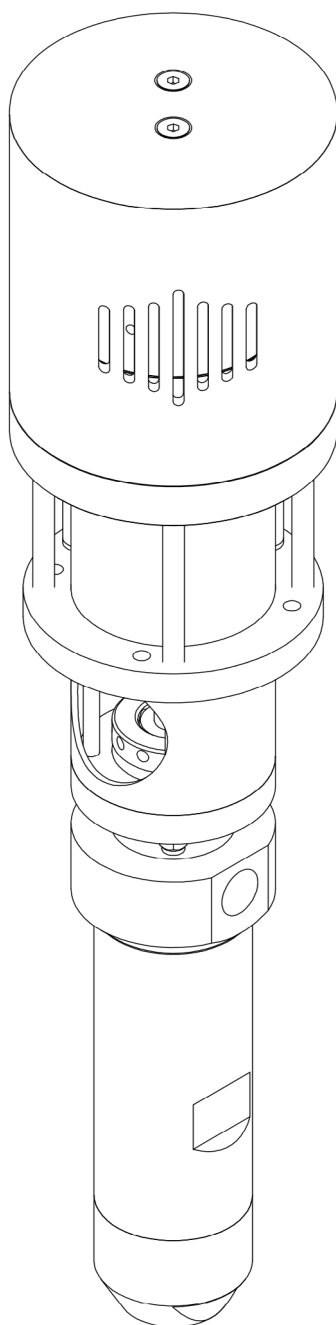

Owners Manual Pneumatic Airless Pump Fluid Transfer



FILTERMEDIA S.R.L.
Via XXV Aprile 1, Monte Marengo 23804 (LC)
Tel. +39 0341 63.01.84 Fax +39 0341.60.87.07
Web: www.filtermediasrl.com

Dear Customer,

First of all, thank you for choosing a product FILTERMEDIA S.R.L.

Our company aims to be a landmark in the paint spraying equipment's. FILTERMEDIA S.R.L. production is synonymous with reliability and safety, our quality control system allows us to guarantee reliability and quality of the components. All parts and components have been designed and manufactured to ensure the best performance.

To maintain a high quality level and long-term reliability we suggest you to use only original spare parts.

All FILTERMEDIA spraying equipments have the EUROPEAN CERTIFICATION according to directive 89/392.

We believe we meet in this way all requirements for safety and reliability and to improve further on the quality of work.

All spraying equipment have a identification's plate conform to CE Directive, and also together with the equipment is attached the operating manual and the CE Certification with European Directive 89/392 and its amendments.

The Management

The following manual is a document that accompanies the machine throughout its lifetime. It is, therefore, an integral part of the machine. Carefully read the following warning and procedures before engaging IN ANY ACTIVITY with the machine, including handling gun unloading it from its transportation mean. For easier references, this instructin manual has been divided into the following sections:

SECTION 1

Transportation, packing, handling, inspection of the purchased product.

SECTION 2

This section describes the machine, its field of application (the work it can perform) and it lists technical features.

SECTION 3

Machine installation

SECTION 4

Safety precaution

SECTION 5

Start-up procedures, Hints for Airless Spraying, Tip selection chart.

SECTION 6

Cleaning Insuctrions

SECTION 7

Maintenance & Service

SECTION 8

Troubleshooting

SECTION 9

Explosion Drawing & Spare Parts List

SECTION 10

Machine storage.

SYMBOLS USED

Those operations which, in order to avoid risks, must be performed by trained and authorized personnel are indicated by the following symbol.



USE AND MAINTENANCE MANUAL

INFORMATION LETTER

The following maintenance and instruction manual is an integral part of machine and must always be available to the personnel in charge of using and maintaining it. The operator and the personnel in charge of handling the machine must have knowledge of the contents of the manual. The descriptions and illustrations in the manual are not to be considered as binding. Although the main features of the machine described in this manual are not subject to change, FILTERMEDIA S.R.L. reserves the right to change those components, details and accessories it deems necessary to improve the machine or to meet manufacturing or commercial requirements, at any time and without updating this manual immediately.



WARNING

ALL RIGHTS ARE RESERVED. The reproduction of any part of this manual in any given form, without prior written authorization from FILTERMEDIA S.R.L., is strictly forbidden. The content of this manual can be modified without prior notice. Great care has been taken in collecting and checking the documentation contained in this manual in order to make it as complete and comprehensible as possible.

FILTERMEDIA S.R.L. machines are not designed to function in areas at risk of fires and/or explosions. For problems or information call FILTERMEDIA S.R.L. customer care technical service or your local dealer.

CUSTOMER CARE TECHNICAL SERVICE

FILTERMEDIA S.R.L.

Via XXV Aprile, 1

23804 Monte Marenzo (LC) Italy

Tel. +39 0341 63.01.84

Fax +39 0341 60.87.07

Web: www.filtermediasrl.com



WARNING:

The machine original configuration must not be modified in any way.

On receiving the machine make sure that:

- The packaging is intact and undamaged
- The supply corresponds to what has been ordered.
- In case of damage please call FILTERMEDIA S.R.L.

SECTION 1

1.1 PACKAGING

To transport the machine in Italy and abroad, the unit is packaged in a cardboard box. All optional components (pipes, suction components, gravity tank) are placed with the machine in the same cardboard box.

The box is fairly light and can be hand-lifted; this prevents any bumps which could damage the machine inside it.



WARNING

Do not dispose of the packaging in the environment.

1.2 TRANSPORTATION

To transport the unit use a trolley. Do not transport more than one at a time. Warning: the packaging of a pump on a trolley is 1000 mm (39.37 in.) high and 700 mm (27.56in.) wide.



1.3 STORAGE

When transporting and storing the machine make sure the surrounding temperature remains between -15 and 40° C. if transportation or storage operations last 24 hours or less do not exceed 50°C or the unit could be damaged.

If the need arises to store the machine, make sure the humidity values in the storage area remain between 30 and 80%

SECTION 2

2.1 MACHINE DESCRIPTION

The manufacturer's identification and CE no. 89/392 conformity is placed on the junction rib of the two bodies.

The plate must be not removed at any time even if the machine should be sold again. Always refer to the serial number (reported on the plate) When contacting the manufacturer. Varois safety drawings are located in the same place, the warnings conveyed must be carefully observed by everyone using tis machine. The company is not to be held responsible for damage to property or accidents to people which might occur if the above-mentioned warnings are not observed. In such a case, the operatore is the only person responsible.

MACHINE DESCRIPTION

Balls	Stainless Steel
Ball Seats	Tungestn Carbide
Packing set	Poly + Leather

2.2 STANDARD AND OPTIONAL COMPONENTS

The machine is delivered with the following standard components:

- * Pump
- * Use and maintenance manual.
- * Declaration of conformity to CE RULINGS.
- * Warranty certificate.

On request:

- * Connection Hoses
- * Paint suction hoses
- * Gravity tank
- * Self- Cleaning tip
- * Spray gun

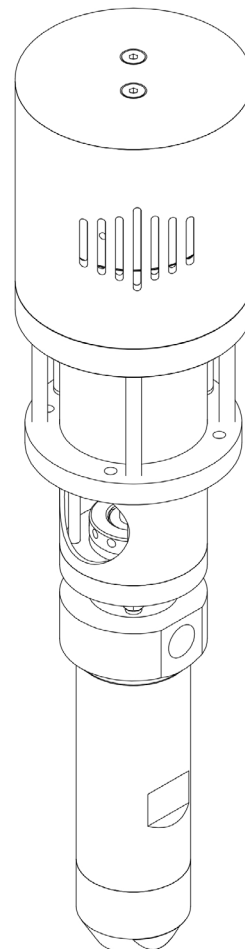

SECTION 2

PUMP TYPE:

These units are airless pneumatic piston. The air motor is ruggedly built in order to keep maintenance to a minimum. All paint valves are made of tungsten carbide for extra long abrasion resistance. The advantages of this type of pump is:

- Accurate spray pattern with minimal overspray
- Minimal or no thinning of paint products
- Pumps straight out of original paint container
- Variable pressure from 0 to 220 bar
- Various nozzles are available for slow to fast spraying
- Light weight, compact and portable
- Quiet running and low power consumption
- Steady spraying pressure
- No fan fluctuations
- Compact paint pump
- Quick cleaning, less parts to wear

HOW PNEUMATIC AIRLESS PUMPS OPERATE:

FILTERMEDIA pneumatic airless pumps are double effect, which is based on a system called "double shaft"; the piston is in movement between two packing fixed or mobile. The paint piston is covered by special treatment in hard chrome or tungsten carbide (according to the type of pump) in order to obtain the best resistance and less wear.

The two valves are made in tungsten carbide. The packings set can be composed in several ways, the mostly used are mixed: polyethylene-leather.

About the paint part, there are different versions: stainless steel treated with chemical nickel, stainless steel or aluminium anodized, according to the needs.

The results are minimal power draw, excellent trigger paint pressure response, no fan fluctuations, and minimal all-around wear

SECTION 3

3.1 INSPECTION OF PURCHASED PRODUCT

Inspect the equipment before using it to check for damage caused by transportation or improper storage. Make sure that all standard and optional components have been delivered.

3.2 INSTALLATION CONDITIONS

The machine does not require special installation procedures; just read the following warnings carefully.



WARNING

Do not place the machine near flammable products.



WARNING

The paint container must be placed near the machine.

3.3 EQUIPMENT AND CONDITIONS NEEDED TO WORK

Painting operations **MUST** be carried out in an appropriate booth equipped with a filtering system. Do not use the unit if the filtering system is not activated. Always wear protective gloves, goggles, breathing filters with active carbon and adequate clothing for the protection of the entire body. All the machine standard hoses are made of antistatic material.

****** Warning ******

COMPRESSED AIR SETUP

The system is compressed air driven. Even though the design of the motor does not require it necessarily, it is advisable to utilize compressed air, properly filtered and free from humidity. In this way the sealing joints of the air motor will have a longer life.

ICE FORMATION

The great advantage of the system is the considerable reduction of ice formation on air purging. Nevertheless, at very low temperatures, it is necessary to use lubricated air with antifreeze, for safety's sake.

LUBRICATION CHAMBER

The paint pump, a compact construction, is screwed to the air motor. The space between the air motor and the paint pump works as a lubrication chamber. Oil coming into this chamber rinses and lubricates the pumping piston on every stroke. Consequently, it is impossible to get incrustations in the piston rod. Packings result protected and avoid the problem of seizing.

SECTION 4

4.1 SAFETY ROULINGS TO FOLLOW DURING USE

TO use the painting unit STRICTLY OBSERVE the following precautions and safety criteria.

FILTERMEDIA S.R.L. declines every responsibility whatsoever in case the user does not observe said precautions and safety criteria; furthermore, it is not responsible for any kind of negligence during the use of the equipment.

WARNING

As it is not possible to protect the working area around the installation and consequently the operator from sudden hose ruptures or elements under pressure, IT IS MANDATORY TO CHECK THAT:

- All the components are not worn-out or damaged.
- The filter fittings and joints are tight.
- Always wear protective gloves, masks, breathing filters with activated carbon and adequate clothing for the protection of the entire body.
- The unit is employed with paints and thinners which are highly inflammable; therefore, use the machine in well ventilated areas and avoid any action which might start a fire (eg. smoking, high temperature slags or shavings, sparks or electric elements). Static electricity can be developed by airless spraying. Ground unit and object to be sprayed. On electric units, unit power cord must be connected to a grounded outlet. Use only three wire extensions cords. Static explosion can occur with ungrounded unit.
- CHECK the chemical compatibility of the products on their technical safety charts. Further information on the materials which make up the unit are available, on request, from FILTERMEDIA S.R.L.
- The use of products which contain organic solvents might cause intoxication from the created toxic vapours.
- DO NOT USE the unit with food or medicines.
- DO NOT EXCEED the indicated maximum working pressure
- BEFORE starting on any dismantling, cleaning, maintenance or assembly operation DISCHARGE the paint pressure in the hoses.
- It is MANDATORY to use the unit inside a painting booth equipped with a filtering system.
- The operator must wear shoes with leather soles or antistatic.
- Never aim the gun at anything other than the surface you intend to spray.
- The unit must be used by one operator only.
- Caution: Static electricity can be developed by airless spraying. Ground unit and object to be sprayed. On electric units, unit power cord must be connected to a grounded outlet. Use only three wire extension cords. Static explosion can occur with ungrounded unit.

Thinners, such as trichloroethane and dichloroethane, can react with the aluminum, with which the great part of the pump and the spray gun are made and can even cause dangerous explosions. Always read the paint technical data very carefully and avoid using materials which contain said thinners. Do not use chlorinated thinners to clean and/or reduce paints. Make sure that the regenerated thinners (diluent for cleaning) used are acid-free: these acids are due to the regeneration and are responsible for the pump and spray gun corrosion.

DO NOT USE the unit with HALOGENATED HYDROCARBON thinners (eg. Ethylchloride, Trichloride, etc.) which might explode when coming into contact with aluminum or galvanized parts.

SECTION 4

4.2 NORMAL USE

Using the unit in a different way than indicated by the manufacturer (Section 2.5) could damage the equipment and endanger the operator. The unit is not designed to use dangerous, explosive and/or toxic material. To use materials which differ from the ones indicated by FILTERMEDIA S.R.L. the operator must consult of the manufacturer.

4.3 EMERGENCY SITUATIONS

FIRE: Use dry powder extinguishers. They must be kept near the equipment as prescribed by LAW (Ruling 626/94 company safety) **DO NOT USE WATER.** Personnel must be trained to know how to deal with success cases.

4.4 SAFETY RULINGS DURING MAINTENANCE

- * Disconnect the electric feed when removing parts of the unit or when replacing any component.
- * Do not wear rings, watches, chains, bracelets etc. during maintenance operations.
- * Always wear individual protective devices (protective gloves, goggles and shoes).
- * Do not smoke
- * Do not use naked flames, pointed elements or pins
- * Use only original spare parts

4.5 MAINTENANCE CHART

Below is a simple CHECK – LIST:

OPERATION	FREQUENCY			CONDITIONS
	Daily	Weekly	Monthly	
Equipment's cleaning	X			
Hoses check	X			
Dump Valve check	X			Operations to be performed with the equipment
Check filters		X		stopped without putting it in work.
Check hoses tightening			X	
Check screw tightening			X	
Check connections			X	
Check wear parts			X	

SECTION 5

Whenever the pump is to be used, it must be prepared for the type of paint to be used. This requires the unit to be flushed out with an appropriate solvent (water for latex, mineral spirits for oil base, etc.). Incorrect flushing can cause gumming of the valves and priming problems.

UNIT PRIMING AND FLUSHING:

1. Check that all hose, gun handle and tip connections are tight.
2. Place trigger lock in "LOCK" position. Connect the air compression hose to the pressure regulating valve fixed on the air motor. Switch on the compressor, adjust the air pressure at about 2 bar.
3. Place dump valve into open or "PRIME" position.
4. Place suction/return tube in correct solvent, or add about one liter of solvent to hopper.
5. Unit will begin pumping and solvent will flow from return tube. Prime for 30 seconds with hopper units, 2 minutes for suction units. If it will not prime, see "inspecting inlet valve."
6. Turn pressure control back to MINIMUM. Close dump valve.
7. Increase pressure to 1/6 of turn. This allows to have a low pressure, ideal for cleaning procedures.
8. Turn pressure control to minimum and open dump valve to release pressure.
9. For suction units, lift both hoses above the level of solvent and turn up pressure two turns to pump out solvent from pump. With hopper units, place return hose into empty solvent container, turn up pressure two turns and allow pump to empty hopper.
10. Disconnect air compressed hose and turn pressure control to minimum. Unit is now flushed out.

PRIMING UNIT IN PAINT:

Follow same procedure as steps 1 - 8 of "Priming and Flushing", but instead using paint. Then continue with the remaining steps as outlined below.

11. Remove tip from gun. Unlock trigger. Aim gun into solvent pail and hold trigger open until solvent flow changes to paint. Release and lock trigger. Re-install tip.
12. Before to work with the unit, test spray pattern on cardboard. Increase or decrease pressure as required for best pattern.

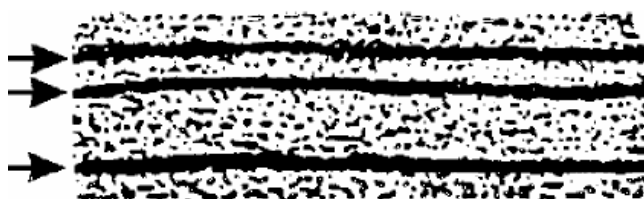

Streaks:

Tip is too small, or paint is too thick



Heavy tailing:

Pressure is too low, or tip is too large.



Even fan:

Correct tip and pressure adjustment.

SECTION 5

WARNING: DO NOT BEGIN SPRAYING BEFORE READING THIS SECTION AND ALL PREVIOUS SAFETY INFORMATION.

PAINTING AND TIP SELECTION:

Correct adjustment of pressure and proper tip selection are crucial to the best spray pattern....

1. In any situation, the lowest pressure that gives an adequate spray pattern is the best pressure to use. It will give maximum pump and tip life and produce minimum overspray.

2. Typically, thicker materials require larger tips and higher pressures than thinner paints do. Some very thick paints may require slight thinning (5-10%) depending upon pump and tip size and application. Generally, thinning is performed when a good spray pattern cannot be obtained with an appropriate tip size at maximum pressure.

SPRAY PAINTING METHOD:

1. Keep the gun perpendicular to the surface. Always hold the gun perpendicular to the surface with the tip approximately 12" from the surface. If held at an angle (up and down or side to side) paint will build up unevenly and leave the work splotchy.

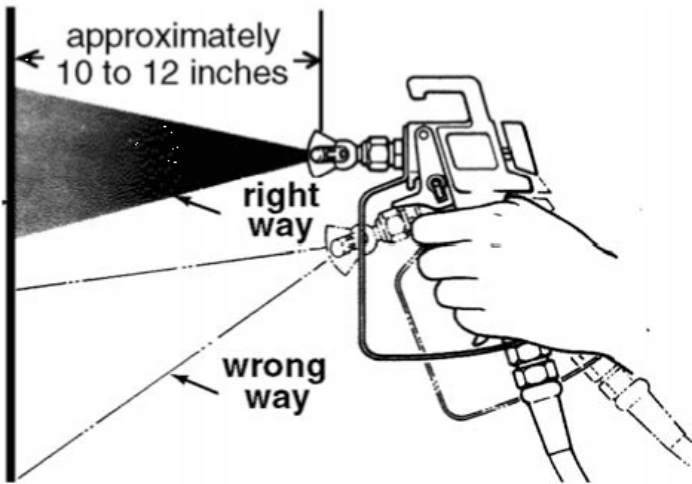

Move with a smooth arm stroke. Move the gun at a steady even pace while keeping the gun perpendicular to the surface. Do not move the gun by flexing your wrist. Fanning the gun will cause excessive overspray and uneven coverage.

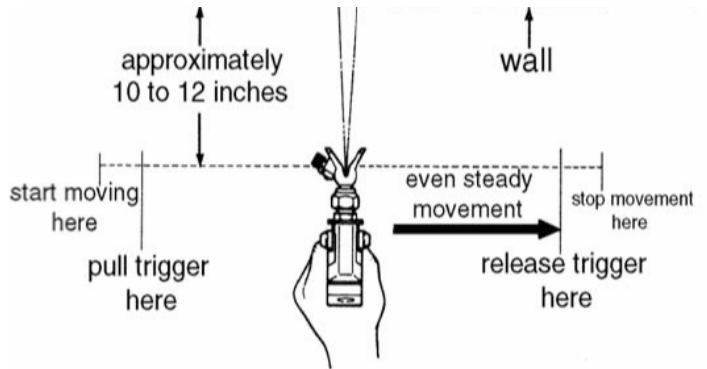

Proper way to trigger spray gun

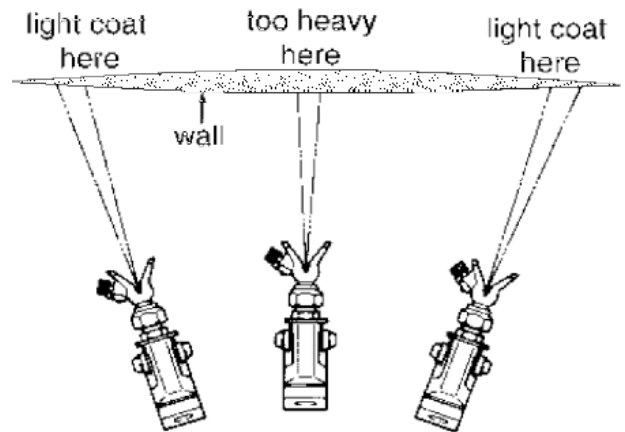

Result of flexing wrist while spraying

3. Start moving the gun before triggering. To get smooth overlap and prevent initial paint buildup, start our stroke movement before pulling the trigger. At the end of the stroke release the trigger before stopping. NOTE: To assure uniform paint coverage, overlap each stroke by 40% - 50%.

4. Intermittent use. If you are spraying and decide to stop for several minutes, lock the spray gun trigger and submerge the tip in a container of the appropriate solvent. This will prevent paint from hardening in the tiny spray opening and clogging the tip. Be sure to release the pressure by opening dump valve and turn off pump.

SECTION 5

SPRAYER:

1. Flush before each use with a solvent that is correct for the paint you will be spraying. ie: Water for latex paints.
2. Clean unit well after each use. A clean unit works better and lasts longer.
3. Flush with mineral spirits when storing the unit for more than 3 or 4 days.

PAINT:

1. Prepare paint according to manufacturer's recommendations.
2. Remove all skins on paint.
3. Stir paint thoroughly.
4. Strain paint through a fine mesh strainer bag to avoid clogging of pump and filters.

SPRAY TIPS:

1. Use minimum pressure that gives a good spray pattern to reduce tip and pump wear and cut down overspray.
2. Replace tips before they become too worn. Worn tips waste paint and overwork the sprayer.

FILTERS:

1. Clean the filters after each use of sprayer.
2. Use correct filter for the tip size and paint type. See tip chart.

PAINT HOSE:

1. **INSPECT THE HOSE PERIODICALLY. DO NOT USE KINKED, WORN OR DAMAGED HOSE. SEE WARNINGS ON PAGES 3 & 4!**
2. Use only hose that is designed for the high pressures of airless units. Minimum working pressure of 240 bar. Be sure it is grounded, static dissipating type hose.
3. Protect both the paint hose and the electric cord from vehicle traffic and sharp cutting edges or objects.
4. For best performance, see the maximum hose length per model at page n. 5. This maximum will largely depend on tip size and thickness of paint.

COMPRESSED AIR SETUP

The system is compressed air driven. Even though the design of the motor does not require it necessarily, it is advisable to utilize compressed air, properly filtered and free from humidity. In this way the sealing joints of the air motor will have a longer life.

ICE FORMATION

The great advantage of the system is the considerable reduction of ice formation on air purging. Nevertheless, at very low temperatures, it is necessary to use lubricated air with antifreeze, for safety's sake

LUBRICATION CHAMBER

The paint pump, a compact construction, is screwed to the air motor. The space between the air motor and the paint pump works as a lubrication chamber. Oil coming into this chamber rinses and lubricates the pumping piston on every stroke. Consequently, it is impossible to get incrustations in the piston rod. Packings result protected and avoid the problem of seizing.

SECTION 5

TIP AND FILTER TABLE

Tip and filter table with specifications concerning capacity at different pressures (lt. minute) with water.
 Notice: For each tip size please choose between the following fan corners

 SELF-CLEANER		CAPACITY MEASURED IN LT/MIN. AT FOLLOWING PRESSURES:				ADVISED FILTER	
Inches (mm)	Spray corner	35 Bar	70 Bar	105 Bar	140 Bar	Nr. Ref.	
0,007 (0,18)	20 °	0,10	0,14	0,17	0,19	69A072	200 Mesh
0,007 (0,18)	40 °	0,10	0,14	0,17	0,19	69A074	
0,007 (0,18)	60 °	0,10	0,14	0,17	0,19	69A076	
0,009 (0,23)	20 °	0,14	0,20	0,25	0,29	69A092	
0,009 (0,23)	40 °	0,14	0,20	0,25	0,29	69A094	
0,009 (0,23)	60 °	0,14	0,20	0,25	0,29	69A096	
0,011 (0,28)	20 °	0,22	0,3	0,38	0,45	69A112	150 Mesh
0,011 (0,28)	40 °	0,22	0,3	0,38	0,45	69A114	
0,011 (0,28)	60 °	0,22	0,3	0,38	0,45	69A116	
0,013 (0,33)	20 °	0,34	0,45	0,56	0,64	69A132	
0,013 (0,33)	40 °	0,34	0,45	0,56	0,64	69A134	
0,013 (0,33)	60 °	0,34	0,45	0,56	0,64	69A136	
0,015 (0,38)	20 °	0,45	0,60	0,75	0,85	69A152	100 Mesh
0,015 (0,38)	40 °	0,45	0,60	0,75	0,85	69A154	
0,015 (0,38)	60 °	0,45	0,60	0,75	0,85	69A156	
0,018 (0,44)	20 °	0,65	0,88	1,10	1,26	69A182	50 Mesh
0,018 (0,44)	40 °	0,65	0,88	1,10	1,26	69A184	
0,018 (0,44)	60 °	0,65	0,88	1,10	1,26	69A186	
0,021 (0,53)	20 °	0,90	1,25	1,55	1,75	69A212	NOT RECOMMENDED
0,021 (0,53)	40 °	0,90	1,25	1,55	1,75	69A214	
0,021 (0,53)	60 °	0,90	1,25	1,55	1,75	69A216	
0,023 (0,58)	20 °	1,05	1,52	1,85	2,15	69A232	
0,023 (0,58)	40 °	1,05	1,52	1,85	2,15	69A234	
0,023 (0,58)	60 °	1,05	1,52	1,85	2,15	69A236	
0,026 (0,66)	20 °	1,30	1,98	2,30	2,73	69A262	
0,026 (0,66)	40 °	1,30	1,98	2,30	2,73	69A264	
0,026 (0,66)	60 °	1,30	1,98	2,30	2,73	69A266	
0,031 (0,79)	20 °	2,00	2,80	3,45	4,15	69A312	
0,031 (0,79)	40 °	2,00	2,80	3,45	4,15	69A314	
0,031 (0,79)	60 °	2,00	2,80	3,45	4,15	69A316	
0,036 (0,91)	20 °	2,65	3,50	3,82	4,55	69A362	
0,036 (0,91)	40 °	2,65	3,50	3,82	4,55	69A364	
0,036 (0,91)	60 °	2,65	3,50	3,82	4,55	69A366	

SECTION 5

FEATURES:

Fast Tip Size Changes - no tools required.

Long Seal Life - withstands harsh solvents - won't swell or leak - replaces in minutes.

Tip Rotates Easily even under "high pressure" clogup.

Safety-Guard - less paint accumulation - helps protect against accidental injection and prevents tip from slipping out of position.

CAUTION: DO NOT USE A NEEDLE OR A SHARP OBJECT TO CLEAN THE TIP

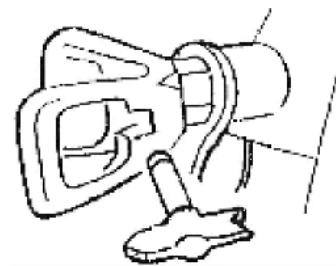

TO OPERATE:

When tip clogs, turn tip handle 180° to "clean out position". Trigger gun and line pressure will purge clog. **DO NOT** spray or empty the hose in "clean out" position, this will cause extreme wear and premature failure. Always remove the tip when cleaning out the hose.

TO CLEAN PLUGGED TIP:

- 1) Rotate the tip to the "Clean" position.
- 2) Pull trigger and spray. This should clear the tip of any blockage.
- 3) Rotate the tip back to the "Spray" position and continue spraying.
- 4) If the clogging continues, clean or replace the gun filter and see the section in this manual on instructions "HOW TO SELECT TIP AND PROPER FILTER"

TO CHANGE UNI-T TIPS:

- 1) Rotate UNI-T 90°.
- 2) Remove from housing.
- 3) Install new UNI-T.
- 4) Rotate 90° to spray position.

TO CHANGE SEAL ASSEMBLY:

- 1) Relieve line pressure and set gun safety.
- 2) Remove tip housing from gun.
- 3) Remove tip from housing.
- 4) Insert a tool into front of housing and press seal assembly out of housing.
- 5) Insert seal into UNI-T head and install seal into guard body from gun nut.
- 6) Install UNI-T tip
- 7) Tighten by hand the gun nut on gun diffuser.

Coating	Viscosity (Centi- poise)	Tip size						
		.009"	.011"	.013"	.015"	.018"	.021"	.023"
Lacquer, varnish, furniture stain	30-70	X	X					
Industrial enamel, stain, colored lacquer	40-160	X	X	X	X			
Shop primer, solid stain, oil base, lated	120-400		X	X	X	X		
Flat oil base, latex	210-600			X	X	X	X	
Thick latex, prepared blockfiller	600-1000				X	X	X	
Most block fillers	1000-3000					X	X	X

SECTION 6

As with all spray equipment, your sprayer must be cleaned properly or it will not operate properly. Clogged valves and filters are the most common causes of problems. If followed, these guidelines will insure trouble free performance from your sprayer.

CAUTION: Clean with water if latex is used. Clean with paint thinners for oil based paints. Both water and paint thinner will be referred to as "solvent" from here on in.

CLEAN UP:

To get the best use and longest life from your sprayer, it is very important to clean it out properly. The procedure is simple and is very similar to the flushing procedure performed earlier. Cleaning and flushing would also be required when changing color, or type of paint, ie: latex changing to oil base.

1. Lock gun trigger, turn pressure control to minimum, open dump valve to release all system pressure.
2. Turn tip to halfway position and remove from gun. (if so equipped).
3. For suction models, lift both suction and return hose above the level of paint in the pail and turn pressure about two turns. Allow unit to pump out paint. (For hopper models, place return hose into paint container and turn up pressure about two turns. Allow unit to pump out remaining paint in the hopper. Place return tube back into hopper).



PUMP FLUID OUT

4. Place suction/return hose into pail with proper solvent to flush out paint and allow unit to prime in the solvent. Clean the outside of metal suction tube. (For hopper units, add about one liter of solvent into the hopper and allow unit to prime. While unit is priming, wipe or brush inside of hopper to dissolve paint).

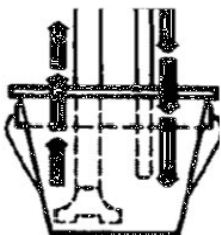

CLEAN PUMP WITH SUITABLE SOLVENT

5. Turn pressure control to minimum and close dump valve.

6. Unlock trigger, and with spray tip still removed and starting with minimum pressure, aim gun into paint container and hold trigger open until paint flow stops and solvent flow just begins. Release trigger. Aim gun into solvent pail/hopper and circulate solvent for about two minutes. To reduce splashing, direct the fluid stream along inside of bucket at a side angle and well above the fluid level (or submerge the tip in the solvent). Release trigger. Point spray gun into an empty waste bucket and spray at least 1 liter of fluid into it.



Pump until clean solvent appears

Warning: conductive metal containers must be used when flushing flammable fluids through the system. Always flush at low pressure with spray tip removed. A metal part of the spray gun must be held firmly against the grounded metal pail when flushing or relieving pressure from the gun.

7. Pump solvent out by lifting both suction and return hose out of the solvent. Turn pressure control to minimum and open dump valve to release system pressure and turn motor off. Lock trigger and clean spray tip before installing back onto gun

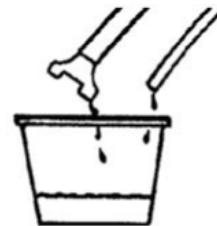

8. Follow above steps 1-7 using clean solvent to completely flush unit. You may at this time, if you wish, blow compressed air into the tip (dump valve open and motor off) to push the solvent all the way out the return hose.
9. If changing paint types, ie: latex (water base) to oil base, you would have to flush unit with clean mineral spirits using above steps 1-7. This would prepare the pump for the oil base paint. Water would have to be used as a last flush if changing from oil base paints to latex.

SECTION 6

10. Ensure pressure control is turned to minimum and all pressure is released. Open dump valve. Disconnect the pump.

11. Unthread gun handle from gun body to access gun filter. Remove filter and brush clean with appropriate solvent. Inspect filter for pin holes, plugging, or other damage. Replace if required. Re-install with "double lip" end pointing up into gun. Lightly grease handle threads (petroleum jelly, auto grease) and re-install firm hand tight. Brush exterior of gun clean.

12. Remove intake screen on metal suction tube or hopper and brush clean, re-install.

13. Storing unit for more than 3 days. If unit was cleaned with an oily paint thinner, the unit is now ready for storage (after step 14). If unit was cleaned with water or a strong thinner (ie. lacquer thinner) pump mineral spirits through the entire system by repeating step 8. If it is not available, drain all the solvent out of the hose, gun, and pump. (Tungsten carbide parts in the valves will corrode if left in water for long periods of time). With the pump running in the prime mode, oil the suction valve. Let the pump run until it spits oil drops out the return fittings. This will displace any remaining solvent and lubricate the valves for storage.

14. Coil up electrical cord and spray hose, inspecting both for signs of damage. Suggested minimum coil size for 1/4" paint hose is 18 inches.

DO NOT COIL PAINT HOSE TOO TIGHTLY. THIS MAY CAUSE KINKS, WHICH WEAKEN THE HOSE. A PAINT HOSE WITH KINKS OR OTHER DAMAGE SHOULD BE CONSIDERED UNSAFE AND BE REPLACED IMMEDIATELY.

WARNING: DO NOT CLEAN THE SPRAY GUN UNLESS THE PRESSURE HAS BEEN RELEASED FROM THE SYSTEM. SEE PAGES 3 & 4 FOR FURTHER PRECAUTIONS.

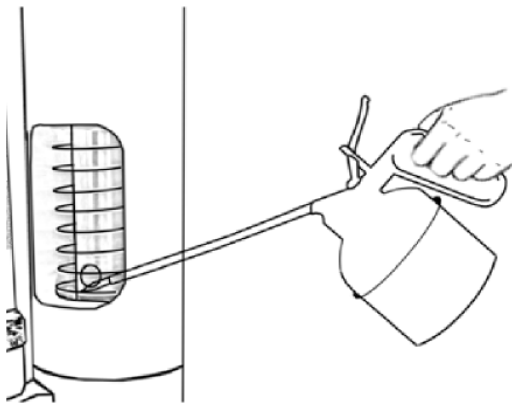

Oil valve before storing

SECTION 7

PAINT HOSE:

Periodically inspect the paint hose. If the hose is kinked, cut, or worn, it must be replaced. It cannot be repaired. A hose bursting at 220 bar (3200 psi) can cause significant damage to property AND cause a serious injury if the sprayA simple way to determinate the wear of the valves is: injects the skin. Replace with a grounded or conductive air-less paint hose that is rated for at least 220 bar (3200 psi) working pressure.

DUMP VALVE:

If the dump valve is not properly cleaned after each use, It will wear prematurely. When worn, the paint will flow through the return hose while the valve is turned to "spray". Spraying pressure will progressively drop as the valve continues to wear. A new valve (or repair kit) should be installed immediately to prevent over working the unit.

Hint... to get maximum use out of the dump valve:

a. Always reduce pressure before turning the handle.

SPRAY GUN:

The filter should be cleaned or replaced after each use to minimize tip clogging problems. If the gun valve becomes worn and begins to leak, it should be replaced. See page 9 for overhaul details.

SPRAY TIP:

The spray tip is one of the most important elements in producing a quality spray job. It requires periodic replacement (every 200-800 ltr) to maintain performance and to prevent overworking the pump (see pages 9-10 for details).

WARNING: BEFORE PERFORMING ANY SERVICE OPERATIONS, DISCONNECT SPRAYER, RELEASE PRESSURE BY OPENING DUMP VALVE

MAIN INSTRUCTION

Pneumatic airless pumps should receive routine servicing after approximately 1.000 hours of use or earlier if there is excessive leakage from the top packing, or if the pump strokes become faster on one stroke or the other. The use of Lubrisolv is recommended as an upper packing lubricant. Do not substitute oil, water, or solvent for an upper packing lubricant.

INLET AND OUTLET VALVES:

The inlet and outlet valves are wearing parts. The rate of wear depends on the type and quality of paint you use. Average life expectancy is about 2000 ltr.

A simple way to determinate the wear of the valves is:

1. With the unit ON and in "spraying position", pull the trigger.
2. During the upper stroke of the piston, release the trigger. If the piston movement do not stop, but it continues up to the end of its stroke, it means that the outlet valve have wear.
3. Viceversa, During the lower stroke of the piston, release the trigger. If the piston movement do not stop, but it continues up to the end of its stroke, it means that the inet valve have wear.

LOWER PACKINGS:

No regular service required.

The lower packings of these units are mobile or fixed.

The lower packing are self-adjusted by the lower conical spring. Wear can be manifested through a drop of pressure. Attention: first be sure that the tip is not worn; this can cause a drop in spraying pressure as well.

UPPER PACKINGS:

Lubricate daily with oil.

The upper packings are self-adjusted by the upper conical spring or manually by screwing the proper nut (APOLLO 66 - APOLLO 48 - APOLLO 263). Wear can be manifested through a loss of material from the upper part of central body.

IMPORTANT NOTE: Both packings are included in the upper & lower packing kit, and should be changed together for best reliability and performance.

SECTION 8

Provided you have followed the instructions, the sprayer will operate efficiently and give trouble-free service. Should any unexpected problem arise you can, in most cases, remedy the problem by following the chart below. If you find that you cannot correct the problem, then take the sprayer to your nearest authorized service agency. Many of the “causes” listed are unlikely to happen. However, all are included in an attempt to cover every possibility.

IT IS ABSOLUTELY ESSENTIAL FOR TROUBLE-FREE OPERATION THAT YOUR AIRLESS SPRAYER BE KEPT CLEAN AND FREE OF RESIDUAL PAINT BUILD-UP ON THE INTERNAL PARTS. IT MUST BE CLEANED AND LUBRICATED AFTER EVERY USE

PROBLEM	CAUSE	REMEDY
Pump does not prime	<ul style="list-style-type: none"> a. Plugged tip b. Gun/line filter clogged c. Suction valve stuck d. Pneumatic motor jammed 	<ul style="list-style-type: none"> a. Clean according to instructions b. Clean filters, rinse out and use thinner materials c. Poke valve free d. Apply to FILTERMEDIA service
Paint pressure drop	<ul style="list-style-type: none"> a. Foreign matters inside suction valve b. Suction filter clogged c. Gun filter clogged d. Worn-out packings e. Too high viscosity f. Tip too large, not suitable for the pump capacity 	<ul style="list-style-type: none"> a. Clean b. Clean c. Clean d. Replace e. Dilute material f. Replace with a smaller tip
Pump does not work constantly. Variable spray angle	<ul style="list-style-type: none"> a. Worn valves, packing and piston b. Non-backflow valve stuck c. Paint pressure insufficient d. Too high viscosity 	<ul style="list-style-type: none"> a. Replace b. Clean c. Increase air pressure d. Dilute material
Pump works regularly, but does not suck material	<ul style="list-style-type: none"> a. Suction valve stuck b. Air infiltration from suction system c. Suction filter is out of material level d. Dirty suction filter 	<ul style="list-style-type: none"> a. Poke valve free b. Check seal c. Add material d. Clean
Pump works, while gun is shut off	<ul style="list-style-type: none"> a. Worn valves, packings and piston 	<ul style="list-style-type: none"> a. Replace <p style="margin-left: 20px;">Apply to FILTERMEDIA service</p>
Pneumatic motor has frozen	<ul style="list-style-type: none"> a. The large number of piston slaps may cause frost formation b. Large amount of condensate water inside air circuit c. Temperature approaching freeze 	<ul style="list-style-type: none"> a. Use a smaller tip and reduce air pressure b. Install a proper condensate separator c. Lubricate air using anti-freeze oil

SECTION 9

PART LIST AND DIAGRAM APOLLO 303 6:1 AIR MOTOR

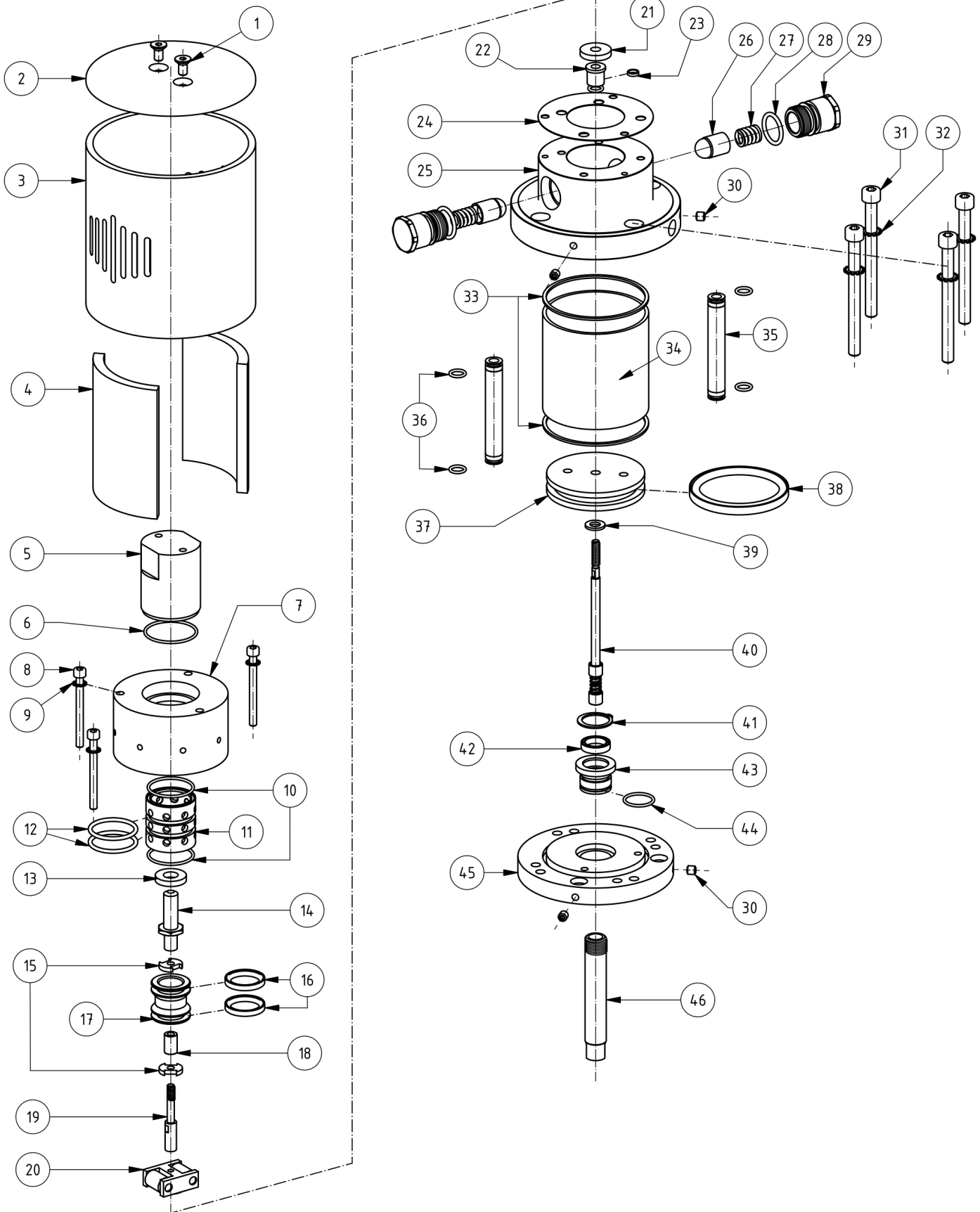

SECTION 9

PART LIST AND DIAGRAM APOLLO 303 6:1 PAINT PART

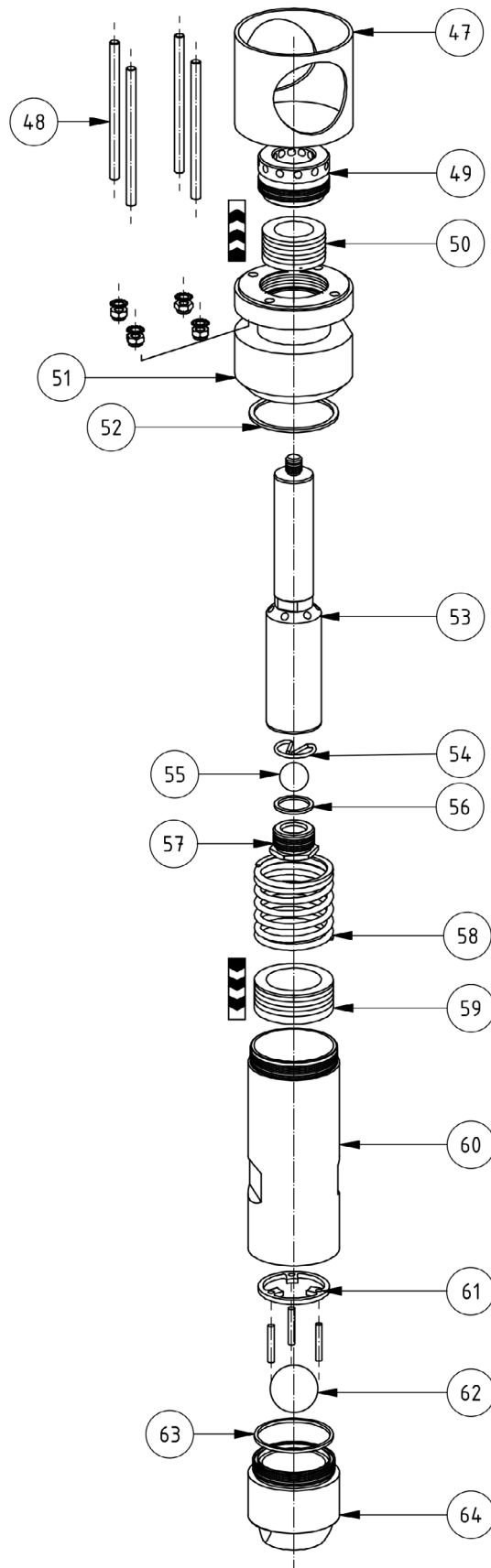

SECTION 9

PART LIST AND DIAGRAM Pneumatic Airless Pumps APOLLO 303 6:1

AIR MOTOR

POS	COD.	DESCRIZIONE	QTA
1	TT3101M1	Vite tappo coperchio T.S. M6x10/ Cover plug screw (2PZ)	2
2	TR24627B	Tappo coperchio/ Cover plug	1
3	TR24627A	Coperchio/ Cover	1
4	TT3106	Copertura fonoassorbente/ Sound proofing cap	1
5	TT3102	Cappuccio completo/ Complete Cap	1
6	TT3102G1	OR 2137 Tenuta cappuccio/ Cap gasket	1
7	TT3107A	Corpo sede spoletta/ Fuse seat body	1
8	TT3107M1	Vite TCE M5X55/ Fuse seat fixing screw (3PZ)	3
9	TT3107M2	Rondella Schnoor Ø5 / Washer Ø5 (3PZ)	3
10	TT3108G1	OR 2118 tenuta frontale camicia/ fuse front gasket (2PZ)	2
11	TT3108A	Corpo camicia/ Seal fuse	1
12	TT3108G2	OR 3118 tenuta laterale camicia/ fuse lateral gasket (2PZ)	2
13	TT3105	Distanziale superiore PU/ Upper Spacer PU	1
14	TT3103	Alberino Superiore/ Upper small shaft	1
15	TT3111	Rondella scaricata spoletta/ Fuse washer (2PZ)	2
16	TT3109G2	Lubroring LRP 4081 + OR 4081 Spoletta/ Fuse gasket (2PZ)	2
17	TT3109A	Spoletta/ Fuse	1
18	TT3110	Distanziale spoletta/ Fuse spacer	1
19	TT3113	Alberino inferiore/ Lower smaller shaft	1
20	TT3115	Gruppo invertitore/ Reversing gear	1
21	TT3117	Paracolpi inferiore PU Completo/ Complete lower buffer	1
22	TT3119	Boccola autolubrificata/ Lubricated Bush	1
23	TT3100G2	Lubroring LRC 2031 + OR 2031 Astina/ Needle gasket	1
24	TT3112	Guarnizione tenuta flexoid/ Gasket flexoid	1
25	TR24602	Flangia superiore/ Upper motor flange	1
26	TT3114A	Corpo Tastatore/ Tracer point (2PZ)	2
27	TT3114C	Molla per tastatore/ Tracer point Spring (2PZ)	2
28	TT3114G1	OR 3075 Corpo pistoncino/ Tracer point O-Ring (2PZ)	2
29	TT3114B	Corpo porta tastatore/ Tracer point body (2PZ)	2
30	TR918	Tappo aria grano M6x6 /	2
31	TR24619	Tirante motore/ Tie-rod screw (4PZ)	4
32	TR2109	Rondella Schnoor Ø8 (4PZ)	4
33	TR24622	Guarniz. di tenuta cilindro	2
34	TR24605	Cilindro Aria/ Air cylinder	1
35	TR24604	Tubo comunicazione aria/ Air hose (2PZ)	2
36	TT3126G1	OR 108 Tubetto Aria/ Air hose O-ring (4PZ)	4
37	TR24115	Pistone Aria/ Air piston	1
38	TR24141	Lubroring LRP 6225/70 + OR 6225 Pistone/ Piston Gasket	1
39	TR24631	Rondella spessoramento	1
40	TR24580	Astina completa/ Complete needle	1
41	TR24159	Anello di arresto/ Seeger	1
42	TR24157	Anello MAD2060/2 / Piston Gasket	1
43	TR24108	Boccola in PTFE/ PTFE Bush	1
44	TR24158	OR 2075 NBR	1
45	TR24603	Flangia inferiore/ Lower flange	1
46	TR24104	Stelo pistone/ Piston rod	1

PAINT PART

POS	COD.	DESCRIZIONE	QTA
47	TR24161	Distanziale motore-pompante / Spacer	1
48	TTR1501	Tirante completo / Complete Screw	4
49	TTR0749	Ghiera pressapacco superiore / Upper packing Pressure	1
50	TTR0750	Pacco superiore / Upper packing	1
51	TTR0751	Corpo centrale pompante / Pumping housing central	1
52	TTR1509	Guarnizione tenuta cilindro / Cylinder gasket	1
53	TTR0754	Stelo pistone / Piston Rod	1
54	TR-18557	Anello fermo sfera / Ball Stop Ring	1
55	TR-18558	Sfera valvola stelo / Rod Valve Ball	1
56	TR-18559	Rondella rame / Copper Washer	1
57	TTR0758	Sede sfera inox /Ball Seat	1
58	TTR0759	Molla pressapacco / Packing Pressure Spring	1
59	TTR0760	Pacco guarnizioni inferiore / Lower gaskets kit	1
60	TTR0761	Cilindro prodotto / Poumping housing	1
61	TR-18654	Fermo sfera valvola aspirazione / Aspiration Valve Stop ball	1
62	TR-18565	Sfera valvola aspirazione / Aspiration Valve ball	1
63	TTR1510	Guarnizione tenuta valvola aspirazione / Aspiration Valve gasket	1
64	TTR1512	Corpo valvola aspirazione / Aspiration Valve	1

SECTION 10

10.1 STORING THE EQUIPMENT

If the need arises to store the equipment for a certain amount of time observe the following instructions:

- Disconnect the unit from the compressed air line
- Thoroughly clean the unit from paint residue.
- Insert thinners in the hoses.
- Cover the unit with a waterproof sheet.

Keep the unit in a dry environment. To preserve all mechanical components the room temperature must be between 15°C and 40°C (59°F and 104°F).

10.2 DISMANTLING

Whenever the need arises to dismantle the paint unit, it is mandatory to observe a few fundamental rules for the safeguarding of the environment.

Protective coverings, flexible pipes, plastic or non-metal material should be dismantled and disposed of separately. The machine DOES NOT CONTAIN POLLUTING OILS but residue paints must be disposed of at authorized waste disposal sites



WARRANTY

All FILTERMEDIA S.R.L. appliances are guaranteed for a period of 12 months from the date written on the invoice, unless otherwise stated in writing. The warranty covers all manufacturing faults and material defects. Replacements and repair operations are covered only if carried out by our company and at our servicing shops.

The faulty parts must be sent CARRIAGE FREE.

Once the components have been repaired they will be sent CARRIAGE PAID to the customer.

The warranty does not cover our company personnel aid during installation or dismantling operations. If for practical purposes one of our employee is sent to the premises, a charge will be made for the time plus extra for travelling and expenses.

Our warranty does not cover direct or indirect damage, to people or property, caused by our appliances and it does not cover repair operations carried out by the owner or by a third party.

The following are not covered by our warranty:

- failure caused by incorrect use or assembly. “ failure caused by external agents.
- failure caused by lack of maintenance or negligence.

WARRANTY FORFEITURE:

If the form attached below is not filled out and returned.

In case of delayed payment or other contract defaults.

All repair operations carried out under warranty do not interrupt its duration.

Whenever changes or repairs are carried out on our machinery without prior authorization Whenever the unit seems tampered with, dismantled or previously repaired in unauthorized servicing shops.

Whenever the serial number is damaged or removed.

When the damage is caused by improper use or functioning, or if the machine falls, is bumped or by other causes of malfunctioning not due to normal working conditions

All disputes will be settled in the court of justice of LECCO (Italy).

NAME

ADDRESS

V.A.T. NR

EQUIPMENT TYPE:

SERIAL N°

DATE

STAMP AND SIGNATURE

To be send, completed in all parts (in capital letters), to: FILTERMEDIA S.R.L. Via XXV Aprile, 1 – 23803 Monte Marenzo Z.I. Levata (LC)